

2011

PRODUCT APPLICATION GUIDE



ALL BALLS

Bearings & Components *Racing*

OFFROAD / MX



2011

PRODUCT INFORMATION

OFFROAD / MX

WE MAKE THE PARTS YOUR CUSTOMERS ABUSE EVERYDAY! AT PRICES THEY CAN AFFORD.

*1 KIT TO LOOK UP, 1 KIT TO STOCK, 1 KIT TO PICK.
REPLACE HUNDREDS OF OE COMPONENT SKUs.*

Linkage Repair Kit

AVAILABLE: **OFFROAD/MX**

Includes Lower Shock Bearing Kit!



Swing Arm Repair Kits

AVAILABLE: OFFROAD/MX



Upper/Lower Shock Bearing & Seal Kit

AVAILABLE: OFFROAD/MX

KTM Lower Shock Bearing Kit

AVAILABLE: OFFROAD/MX

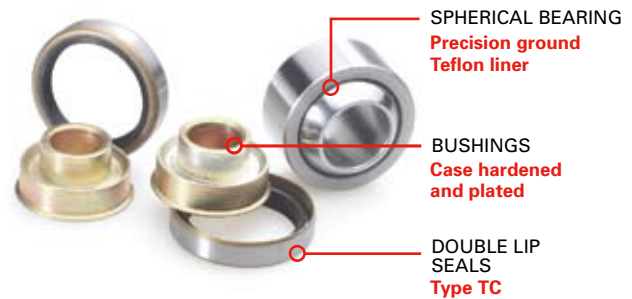
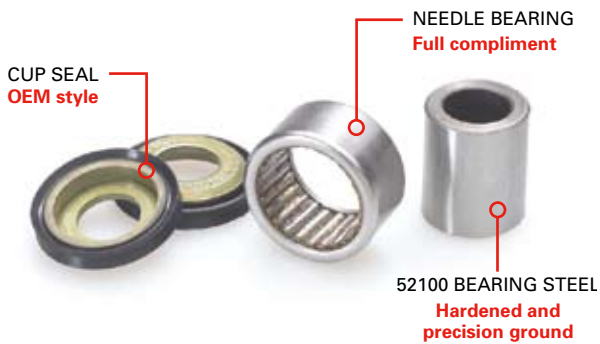

Wheel Bearing & Seal Kits

AVAILABLE: OFFROAD/MX

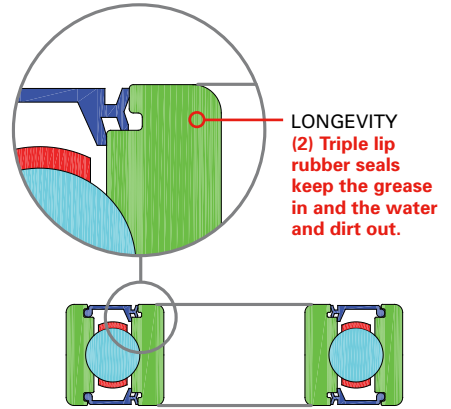

Long Life Wheel Spacers

AVAILABLE: OFFROAD/MX



KTM Rear Wheel Bearing Upgrade Kit

AVAILABLE: **OFFROAD/MX**

- The fix for rear wheel bearing failures.

AB No.: 25-1552

For KTM off-road bikes 125cc and up.



Tapered Steering Bearing & Seal Kit

AVAILABLE: **OFFROAD/MX**

- Direct replacement for OEM tapered bearings.
- Mix and match bearings/seals for front-end conversions.



Crank Shaft Bearing & Seal Kit

AVAILABLE: **OFFROAD/MX**



Long-Life Chain Rollers

AVAILABLE: OFFROAD/MX

OPTIONS: 34mm, 38mm
(Black/Blue/Red/Clear)

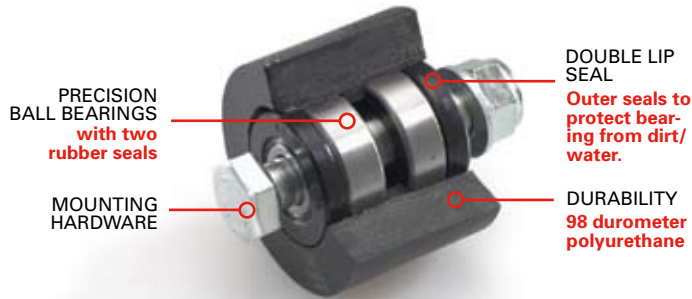

Rear Shock Seal Head Assemblies

AVAILABLE: OFFROAD/MX

- Superior sealing technology
- Complete assembly
- Competitively priced

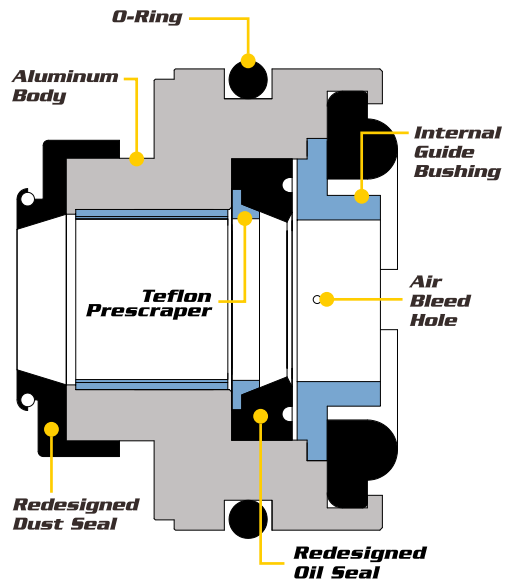

Featuring the same custom elastomer as our fork seals.



Fork & Dust Seals

AVAILABLE: OFFROAD/MX

New Fork Seal Design

- Seal profile is engineered to create equal pressure in each seal lip. Equalized seal pressure creates less drag and longer seal life.
- Patented MAX-LIFE has a coefficient of friction up to 3x's less the OEM seal material.
- Triple lip seal design utilized throughout the entire product line.
- Dyno tested to last 3 to 4 times longer than OEM seals.
- Directional ribs allow seal to be installed easily.

DIRECTIONAL RIBS

Directional ribs allow seal to be installed easily.

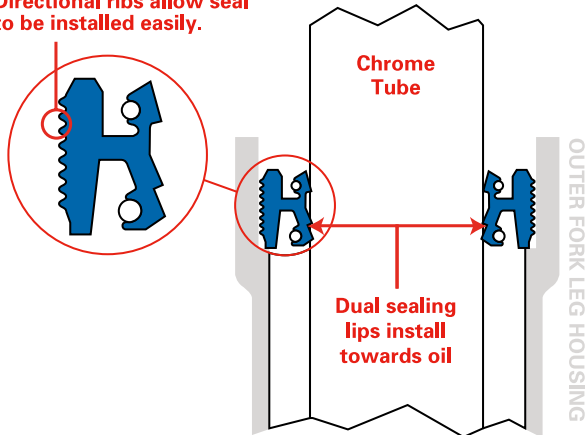

Fork Bushing Kits

AVAILABLE: OFFROAD/MX

- Bushings Dyno-tested to 500,000 strokes with less wear than OEM bushings. Complete bushing kits for all popular Off-Road/MX bikes.
- Includes 2 slider bushings and 2 leg bushings along with all copper washers, o-rings and fork seal snap rings.



TECHNICAL BULLETIN: WHEEL BEARING INSTALLATION

Improper installation can cause bearing damage and dramatically reduce bearing life.

Heating the wheel hub will cause the hub to expand slightly and will make bearing installation easier.

Follow the simple guidelines below to successfully install your All Balls bearings.

Step 1: Apply pressure to outer race.

Apply pressure **ONLY** to the outer race of the bearing.
Apply pressure evenly so the bearing remains square to the wheel hub.

Step 2: Seat the first bearing fully.

Step 3: Place inner spacer between bearings.

Step 4: Tap in second bearing.

Tap the second bearing in until the inner race just touches the center spacer. See (Fig. 1)

FIG 1: CORRECT INSTALLATION (SNUG INNER SPACER)

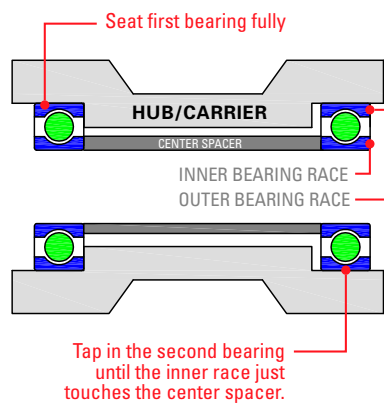

Step 5: Check bearings for side loading.

Fully seating the second bearing may cause both bearings to become side loaded causing premature failure. See (Fig. 2)

FIG 2: INCORRECT INSTALLATION (TIGHT INNER SPACER)

Fully seating the second bearing will cause the bearings to side load causing premature failure.

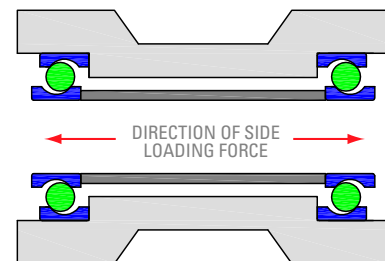

Step 6: Check center spacer.

If the center spacer is loose after the second bearing is installed this may be a sign that the center spacer is too short and needs to be replaced or the second bearing needs to be taped in further.

A loose or worn center spacer can cause the bearing to be side loaded in the opposite direction after the axle is torqued down. See (Fig. 3)

FIG 3: INCORRECT INSTALLATION (LOOSE INNER SPACER)

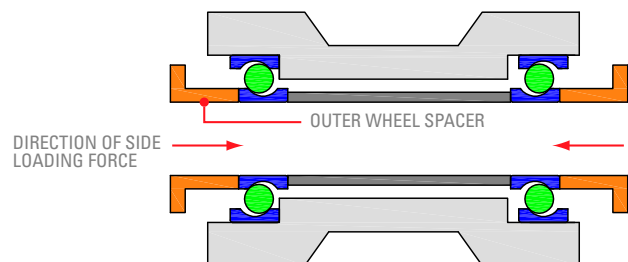

ALL BALLS DISTRIBUTOR LISTINGS

USA

Automatic Distributors
T: 800-341-1658
F: 800-548-2221
www.autodist.com

KK Motorcycle Supply
T: 800-543-9638
F: 937-222-9387
www.kkrace.com

Marshall Distributing
T: 800-248-0136
www.marshalldistributing.com

MTA Inc
T: 318-255-0049
F: 318-255-3882
www.mta-la.com

Performance Tire
T: 800-523-2542
F: 800-557-4670
www.performancetireinc.com

Parts Unlimited/Moose
T: 800-369-1000
www.parts-unlimited.com

Southern Motorcycle Supply
T: 858-560-5005
F: 858-560-4626
www.southernms.com

Tucker Rocky/Quad Boss/MSR
T: 800-347-1010
www.tuckerrocky.com

Western Power Sport
T: 800-999-3388
www.wps-inc.com

CANADA
Gamma Powersports
T: 800-461-0271
F: 800-598-8663
www.gammasales.com

Les Importations Thibault
T: 819-569-6212
F: 819-563-8058
www.importationsthibault.com

Kimpex
T: 819-472-3326
www.kimpex.ca

Motovan
T: 800-363-0808
F: 888-449-7773
www.motovan.com

Parts Canada
T: 800-661-3878
F: 800-661-5015
www.partscanada.com

AUSTRALIA
A One Accessories Pty Ltd
T: 617 3806 1800
F: 617 3806 1755
www.a1accessory.com.au

East Coast Custom (V Twin)
T: 617 3252 4633
F: 617-3252 3138
www.eastcoastcustom.com.au

BELGIUM

Motana / Moteo N.V. / S.A.
T: 03.20.08.64.08
F: 03.20.08.64.07
www.moteogroup.com

Rino Trading
T: 015 228 433
F: 015 230 628
www.rinotrading.be

BRASIL
Brasil Racing
T: 55 (11) 3951 4571
www.brasil-racing.com.br

BULGARIA
Motoshop 1
www.motoshop1.com

COLUMBIA
Yamaha Motowork
T: 574-3121140
www.yamahamotowork.com

CZECH REPUBLIC
Motopoint
T: 420 493 722 248
F: 420 493 720 474
www.motopoint.cz

ECUADOR
EDMONZAR. CIA. LTDA
T: 5937 2868345
F: 5937 2865838
www.factoryacce.com

FINLAND
All Right Europe
T: 3589-8770-5036
F: 3589-8770-5098
www.allrightmx.eu

FRANCE
Bihir S.A.S.
www.bihir.eu

Moto Evasion
T: 33.3.88 87 40 87
F: 33.3.88 87 40 60
www.motoevasion.com

GERMANY
TMF Racing
T: 49 700863 72246
www.tmf-racing.de

Zap Technix
T: 49 36425 50306
F: 49 36425 50307
www.zap-technix.com

Zupin
www.zupin.de

ICELAND
JHM Sport ehf
T: 354 5676116
F: 354 5872435
www.jhmспорт.is

ITALY

IRO Auto (ATV)
T: 39 (0)125 - 617242
F: 39 (0)125 - 251781
www.iorauto.it

Mototime SRL (MX)
T: 290365714
F: 290278198
www.mototimemx.it

LITHUANIA
UAB Motopoint Baltic
T: 37061034419
www.motonet.lt

NETHERLANDS
Haan Wheel
T: 31 73-5495470
F: 31 73-6110273
www.haanwheels.com

Zodiac (V Twin)
T: 31-(0)297 28 86 21
F: 31-(0)297 28 82 26
www.zodiac.nl

NEW ZEALAND
W. White Wholesale Ltd
T: 64 7 849 5493
F: 64 7 849 6493
www.whites.co.nz

NORWAY
Norsk Motor Imports
T: 67920380
F: 67972855
www.norskmotorimport.no

PARAGUAY
GRUPO GIGA S.A.
061 503980
www.giga.com.py

POLAND
Olek Motorcykle
T: 0 32 210 70 13
F: 0 32 212 76 86
www.olekmotorcykle.com.pl

PUERTO RICO
2 Ruedas Distributor
T: 787-735-4671
F: 787 383 8147

PORTUGAL
BICIMOTOR, LDA
T: 222008785
F: 222084124
www.bicimotor.pt

ROMANIA
Motopoint Pontic S.r.l.
40 742 029 349
www.motonetro.ro

RUSSIA
1 RMC (street)
www.1rmc.ru

Pilot Moto Ltd
T: 7 812 331-01-17
www.pilotmoto.com

SPAIN

Hesperia Internacional S.L.
T: 91-508-8830
F: 91-508-9537
www.hesperiainternacional.com

MOTING PARTS, S.L.
T: 34 972 100 974
F: 34 972 980 552
www.motingparts.com

SLOVAK REPUBLIC
Motopoint SK
T: 421 475 6922 152
www.motonetsk.sk

SLOVENIA
Motopoint Adriatik d.o.o.
T: 38 640 385 044
www.motonet.si

SOUTH AFRICA
Henderson Racing
T: 27 83 602 1063

SWEDEN
Knobby
T: 46-431-14411
F: 46-431-10142
www.knobby.se

UK
Off Road Only Ltd
T: 44-1597-822666
F: 44-1597-825224
www.oro2u.com

Apico International
T: 0870 777 9201
F: 0870 777 9202
www.apico.co.uk

UKRAINE
Europarts
www.europarts.com.ua

H-D REPLACEMENT (USA)
Bikers Choice
T: 800-347-1010
www.bikerschoice.com

Custom Chrome
T: 800-729-3332
www.customchrome.com

Drag Specialties
T: 800-369-1000
www.dragspecialties.com

Mid-USA
T: 800-632-0024
www.mid-usa.com

Tec Distributing
T: 800-696-1340
www.tecdist.com

Brute Force KVF 650i & 750 Upper & Lower A-Arm Upgrade Kit

AVAILABLE: **UTILITY**

Upper & Lower A-Arm Upgrade Kit Contains the Parts Needed for all Four Front A-Arms.

- The OEM design incorporates small spherical bearings that carry the thrust load of the entire front end of the machine.
- As the spherical bearings become loose, the external seals become ineffective due to excess play—allowing contamination to pass into the assembly.
- The upgrade kit contains parts for the entire front end of the machine. Field tested for proven durability.

APPLICATIONS:

Kawasaki

2006 - 11	KVF650i Brute Force	50-1059
2005 - 11	KVF750 Brute Force	50-1059

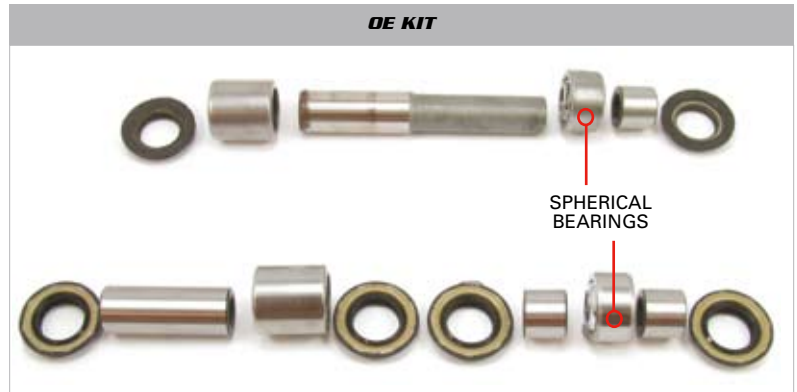

A-Arm Conversion Kit

AVAILABLE: **UTILITY | SPORT**

- Many utility ATVs use rubber bushings as A-Arm bearings. The All Balls Upgrade Kit utilizes Acetal thermoplastic resin bushings with integrated seals and hardened steel pins for longer service life. This kit provides greater suspension travel and performance.

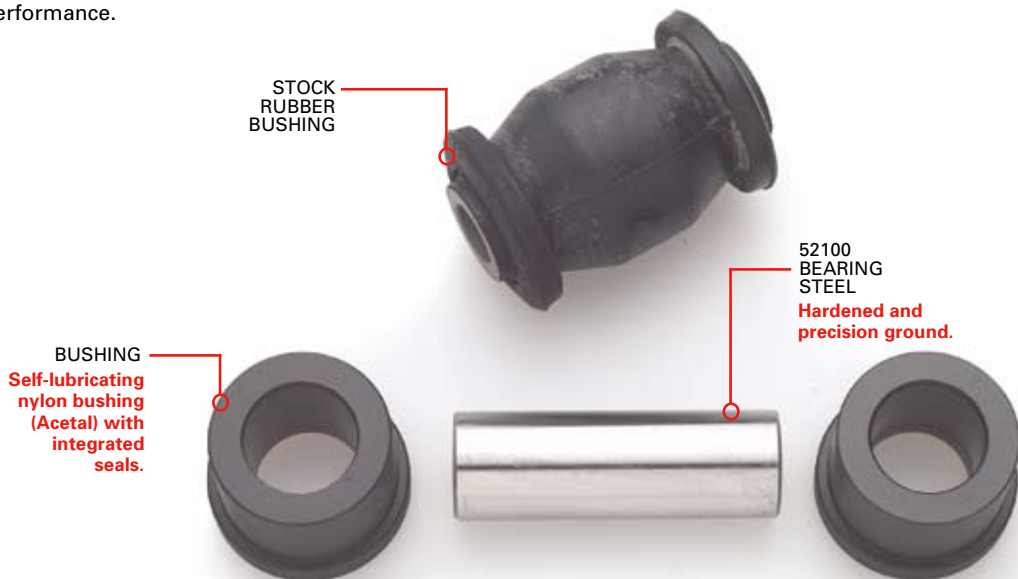

A-Arm Repair Kit

AVAILABLE: *UTILITY | SPORT*

- Rebuilds 1 A-Arm.

TYPICAL ILLUSTRATION:

All Balls A-Arm Repair Kits are Direct Replacements for the OE Configurations.



Rear Independent Suspension

AVAILABLE: *UTILITY | SPORT*

- All the parts required to rebuild one side of an ATV rear suspension. (Upper and Lower A-Arm and Knuckle)



12mm Tie Rod Upgrade KitAVAILABLE: *UTILITY / SPORT*

- Upgrade failure-prone 10mm tie rod ends to heavy duty 12mm ends.
- Kit includes all of the parts required for the conversion.
- Retailers for less than the cost of replacing 4 OEM 10mm tie rod ends.

**Heavy Duty Tie-Rod End Kit**AVAILABLE: *UTILITY / SPORT*

- Kits include 2 tie rod ends.
(1 LH thread, 1 RH thread)



HEAVY DUTY
Steel and aluminum
 housings have been
 strengthened in
 critical areas.

Crank Shaft Bearing & Seal Kit

AVAILABLE: UTILITY | SPORT



Koyo

PRECISION
 CRANK
 BEARINGS

DOUBLE LIP
 SEALS WITH TEFLON
 CONTACT AREA

Less wear on the
 crankshaft pin.

Can tolerate a "dry
 start" without failure.

Differential Seals

AVAILABLE: UTILITY



Differential Bearing & Seal Kit

AVAILABLE: UTILITY

- All the bearings and seals needed to repair a differential.



PRECISION BALL
 BEARINGS

DOUBLE LIP
 TYPE TC SEALS

MACHINE RACE
 NEEDLE BEARINGS

REPAIR SLEEVE FOR
 WORN PINION SHAFTS
 The pinion shaft can
 be machined and this
 sleeve installed saving
 your customers
 hundreds of dollars.

Sport ATV Rear Carrier Bearing Upgrade KitAVAILABLE: **SPORT**

- Two side-by-side bearings are replaced by one double row bearing.
- This yields a 30% greater load carrying capability and up to 30% greater life.

**APPLICATIONS:**

Eng Ltr	Model No	Year	Rear carrier bearing upgrade kit fits stock carrier.	High performance double row rear carrier bearing kit fits aftermarket carrier.
Can Am				
450	DS 450 EFI/MXC/XXC	2009 - 10	25-1630	
450	DS 450 STD/X	2008 - 11	25-1630	
Honda				
250	ATC250R	1985 - 86		25-1401
250	TRX250R	1986 - 89		25-1401
250	TRX250X	1987 - 88		25-1401
250	TRX250X	1991 - 92		25-1401
300	TRX300 EX	1993 - 09		25-1401
350	ATC350X	1985 - 86		25-1401
400	TRX400EX	1999 - 09		25-1401
450	TRX450ER	2006 - 09	25-1616	25-1401
450	TRX450R	2004 - 09	25-1616	25-1401
Kawasaki				
450	KFX450R	2008 - 11	25-1620	
Suzuki				
450	LT-R450	2006 - 09	25-1619	
Yamaha				
450	YFZ450	2004 - 05	25-1617	
450	YFZ450	2006 - 09	25-1618	
700	YFM700R Raptor	2006 - 11	25-1618	

Wheel Bearing & Seal Kit

AVAILABLE: *UTILITY | SPORT*

- Rubber sealed bearings for additional protection from water and dirt.



Ball Joint Kit

AVAILABLE: *UTILITY | SPORT*





ALL BALLS

Bearings & Components *Racing*

ATV SPORT & UTILITY | UTV

DIFFERENTIAL BEARING AND SEAL KITS



REAR INDEPENDENT SUSPENSION KITS



SWING ARM AND LINKAGE BEARING AND SEAL KITS



SHOCK BEARING AND SEAL KITS



TIE-ROD UPGRADE KITS



TIE ROD END KITS



BALL JOINT KITS

WHEEL BEARING AND SEAL KITS



LOWER STEERING BEARING AND SEAL KITS



A-ARM BEARING AND SEAL KITS

